

MANUAL EMD-30 eco

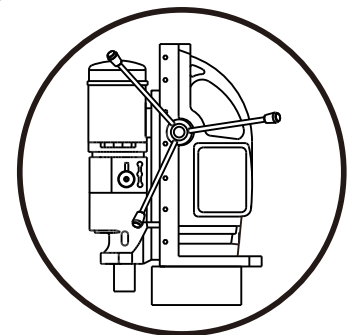

OPERATING INSTRUCTION -28

Warning	1
Thanks To The Buyer	1
About This Manual	1
Descriptions Of Products	2
Cautions	2
Electrical Safety	3
Safety Instructions	3
Instructions	4
Grounding Device	5
Quality Assurance.....	5
Fault Handling	6
Spare Parts List Exploded Drawing	9

Operation Manual

WARNING

To prevent electric shock or fire, please strictly abide by the procedures in the operation manual.

The machine only for the authorized persons, please do not let other people to operate. If any violation of the instructions operation and cause personal injury or machine damage, our company disclaim all responsibility.

The machine can be only maintained by the people who has the certification.

THANKS TO THE BUYER

Thanks for buying the series of magnetic drill machine of . Please read the operation manual and pay attention to the safety precaution.

The right operation, will make you fully feel our products superior performance.

Please put this manual in a safe place for future reference.

ABOUT THIS MANUAL

The machine model of the description in this manual:

OB: EMD-30 eco

Confirm the machine model according to the nameplate.



DESCRIPTIONS OF PRODUCTS

Magnetic drill is a kind of electric tool for adhering and drilling on the horizontal level, side face and top face, and widely used in the building, bridge building, and ship building industries and so on. You can use the magnetic drill when you can not use drill press and electric hand drill to drill huge steel workpieces or in field operation. It's very convenient to use, flexible, can reduce labor intensity, improve the machining precision and work efficiency.

CAUTIONS





1. Please read the manual carefully before use, to understand the magnetic base drill structure; electromagnetic sucker, electric drill and transmission functions.
2. Before installing or remove the drill must confirm the motor switch is closed and unplug.
3. Using a drill bit after clamping, key wrench must be removed, while the drill must be sharp, for Morse taper shank drill should pay attention to the flat iron tail at the cone sleeve waist groove insert cone sleeve. Remove the drill, the inclined flat iron is inserted on the oblique iron just bit dropping hammer sleeve waist groove.
4. And its operation must be put in the fuselage behind the cable, away from the drill bit
5. In the switching power supply, electric and magnetic switch must be in the off position
6. Drilling machine must be used when using engine coolant. The use of cooling liquid (soap) according to the ratio of watered, absolutely can not direct use water cooling. Otherwise very easy to damage, and the main internal rust on the drill bit can't get it out. No internal machine water, otherwise it will burn the circuit board.
7. Such as the use of the stepless speed regulation, models of constant power overload protection, the machine during use motor suddenly stop functioning, then in the function of overload protection device, the steps are as follows: A, turn off the power switch, paused for a few minutes; B, weight of the plug, then open the motor.
8. The use of magnetic base drill, must wear a seat belt buckle.
9. No rough operation personnel, feed can not handle in order to work fast and pressed down the machine feed, so lossy bit and machine
10. Non-magnetic materials can not drill with magnetic base, if the non-magnetic material punching need to choose the magnetic base drill with sucker.
11. Cannot use at the same time, electric welding machine and magnetic base drill on the same piece of steel plate, so that the operating from electric shock danger.



ELECTRICAL SAFETY

Tool before connecting power, using the socket must be able to fit the plug machine. The 380V model to determine the fire and. Line the correct docking, power supply socket with the need of professionals to complete. Do not arbitrarily change the plug, adapter plugs can't pick. The electric tool wire used together.

SAFETY INSTRUCTIONS

Warning labels and/or other labels on the machine must be replaced when they were removed.

	<p>Do not operate the machine at insufficient lighting conditions. Do not operate the machine outdoors. Do not operate the machine when you are tired, when your concentration is impaired, and/or under the influence of drugs, medication or alcohol.</p>
	<p>Climbing onto the machine is forbidden! Heavy injuries by falling down or by tilting of the machine are possible.</p>
	<p>The machine shall be used only by trained persons. Non authorized persons, especially children, shall be kept away from the work area.</p>
	<p>Do not wear loose clothing, long hair openly or loose jewellery like neck-laces etc. when operating the machine They might be caught by rotating parts and cause serious injuries.</p>

	<p>Use proper safety clothing and devices when operating the machine (, safety goggles, ear protectors, safety shoes ...).</p>
	<p>Before any maintenance you have to disconnect the panel saw from the power source.</p>

INSTRUCTIONS

1. Plug the power plug, the drill bit aim at processing position, make the magnetic switch is opened, so that the magnetic is adsorbed on the surface of steel plate magnetic materials. No impurities on the surface, and check whether the attractive force is normal or not. (general plate thickness should be more than 10mm)
2. Please placed the magnetic base drill required from the drilling near site and select the appropriate adsorption material. And will handle hole safety rope penetrates into the frame, the other one is in fastening frame after the penetration of the buckle, and then close the safety rope buckle. Hand and pull off, should not loose and mobile.
3. For a support screw, regulating the support screw that the bottom touches the workpiece surface.
4. For the magnetic base is provided with the angle of the drill, the use of angle wrench movement angle disk in the annex to the belt rack makes bit central alignment processing position, tighten the angle wrench.
5. Open the electric drill switch, check whether the drill bit beat, sound is normal, if everything is normal can turn the handle to feed.
6. Start feeding should be slow, gives the quantity of about 0.05mm/r in general, not too much force, to prevent overload.
7. If the drill suddenly stopped, you must turn off the power switch immediately, (Must close the magnetic control switch)
8. Please shut down for a period of time machine in continuous use for 2-3 hours, in case magnetic base is overheated and leakage or burned.
9. Should be filled with cooling water or cooling liquid using hollow drill, turn on the tap, and let it flow out slowly.

10. The company factory hollow drill are equipped with cooling kettle, please put the kettle arranged on the corresponding position before operating the machine, and tighten the two round head screw. The kettle is connected after please figure two (035), fittings is screwed on the hydrosphere, tighten the end can be on the frame by.

11. After 300 hours of operation, the gear lubricating oil should be replaced.

GROUNDING DEVICE

This tool should be properly grounded, in order to avoid the shock. Grounding device should have the lead standard, and a grounding plug with earthing special line. Do not be ground false joint in the line of fire or three-phase line. Grounded power receptacle should be connected with the earthing device is connected to the eternal, so that it can work with yellow green wire connected to the plug hole and connection piece at the same time and ground connection.

QUALITY ASSURANCE

Consumers buy our machines produced within six months, enjoy free maintenance and warranty service. During normal use of the whole or parts of any manufacturing process or product failures caused by components, please present the original invoice, the dealer stamped and filled properly warranty certificate to the Company or the Company's designated repair station to receive free services. Machine consumable normal wear and tear, overload, do not operate according to operating specifications, disassemble, damage caused as a result of use of parts other than the Company and damage, are not covered by warranty. Warranty expires, provided by the designated repair station maintenance service. Maintenance records must be sealed or signed by the repair station to take effect.

FAULT HANDLING

FAULTS	CAUSES	ELIMINATION METHODS
Magnetic base without suction	Switch contact undesirable	Repair the switch
	Power supply is broken	Repair the power supply
	The fuse burn out	Replace the Fuses
	Electromagnet short circuit or burn out	Repair or replace the magnetic bridge
	Adsorption not on the steel frame	Change the adsorption surface
Machine did not run after the jump	Switch contact undesirable	Repair and change switch
	Joint loose	Check the electric drill part connector
	Brush and commutator poor contact	Repair or replace the electric brush
	Drill the armature or stator coil burn out	Changing the armature or stator
Magnetic little suction	Adsorption artifacts thin	Replace the adsorption surface or thickening adsorption surface (> 10mm steel sheet)
	Adsorption on the surface is small	Replace the adsorption surface or temporary welding thick surface adsorption
	Support bar between the adsorption surface	Support bar top tight
	Diode may be virtual welding	Re Welding
Turn the handle guide does not work	Shaft key cut	Replace the shaft key
	Wheel and rack misplace	Unscrew the rack bottom screw, remove guide to repair
Drill out the elliptical hole	For a drill and a fastener is loose	Correction of verticality tighten the fasteners
	Bit unilateral cutting	Grind anew
	Adsorption surface have sundry	Eliminate clutter
Spindle shake	Frame adjusting screw loose	Tighten adjusting screws
Electric ignition	The spark turns orange.	Slow down.
	Sparks flying out.	Change the brush, please.
	Sparks into a ring of fire	Please check if the motor is burned.

Warning: magnetic drill equipped with a safety rope, when operating, make sure the magnetic drill and the object is fastened by the rope. In case of power failure suddenly, causing the machine fall off or thrown objects and cause accidents.

Attention: Our company does not assume any responsibility because the machine is not solid or fixed safety facilities are not in appropriate place cause accident.

MAGNETIC CORE DRILL

1 > MAGNETIC CORE DRILL SPECIFICATIONS SHEET 1

MODEL	Core drill dia(mm)	Twist drill dia(mm)	Voltage(V)	Frequency(Hz)	Inper power(W)	Max attraction(N)	No-load speed(rpm)	Cutting depth(mm)	Mores taper	Stroke(mm)
3500	35	/	110/220~	50-60	1500	14000	800	30	/	120

Notice: In order to constantly improve products, our company reserves the right to change technical data without prior inform.

2 > MAGNETIC CORE DRILL ADVANTAGE

Magnetic base drill has the advantages of small volume, light weight, high efficiency, easy to carry, host frame material for magnesium alloy die casting machine, The host is fixed to the gear box, the advantages of the built-in cooling system. Motor with constant power, soft start, electronic stepless speed regulation, overload protection and other functions.

Magnetic base drill hole hollow drill is very economic. Control models can not change the bit torque state change. Variable speed, with Morse conversion set of models can be clamped Hemp flowers drill, can be used for many purposes in order to achieve one machine multipurpose high. Greatly improve the working efficiency.

3 > MAGNETIC CORE DRILL APPLICATION

While drilling on horizontal level, move the machine to the workpiece, then plug in. Turn on the magnetic control switch, fit on the bit after the magnetic base fixed firmly, and then rotate the handle to move the bit to the workpiece. Turn on the motor switch to drill. Keep the load around 0.05mm/r. Do not overexert in case of overload.

While drilling on the side face, we need two operators, and one guardian as well. Move the machine to the workpiece, then plug in. Turn on the magnetic control switch until the magnetic base fixed firmly (the operator need to hold the machine during this period), and then fasten the safe belt in case of sudden dropping. Fit on the bit, rotate the handle to move the bit to the workpiece and then turn on the motor switch to drill. Keep the load around 0.05mm/r. Do not overexert in case of overload.

While drilling on top surface, we also need two operators, and one guardian as well. Try not to drill on this way. While choosing this way, take some corresponding protection consider the fastness and the scrap iron. As to other ways, operators can use flexibly according to the situation. But do consider the safety.

No.	Parts Name	QTY
1	Internal Circlip19	1
2	gasket9*19*2	1
3	plastic gasket	1
4	flick	1
5	Spring95	1
6	Spindle 32HD	1
7	Inner Hexagon Flat jackscrew	2
8	Philip's head screw M5*55	4
9	round pin4*12	1
10	water sealφ22*32*7	1
11	Bearing JVB6904	1
12	Flat Board32HD	1
13	External Circlip 16	1
14	Middle Cover	1
15	Internal Circlip42	1
16	Bearing JVB6905	1
17	water sealφ22*32*7	1
18	Gear box	1
19	round pin5*15	2
20	Inner Hexagon screwsM5*20	4
21	Bearing LFB608	1
22	Armature Shaft	1
23	Pin	1
24	armature gear plate42HD	1
25	Bearing LFB608	1
26	O ring φ25.8*1.8	1
27	Bearing NSK6000	1
28	Armature φ42*48	1
29	Bearing NSK6000	1
30	break wind ring 80	1
31	Screw M4*65	2
32	Stator φ75*48	1
33	Stator Shell	1
34	Label	2
35	Carbon Brush	2
36	Brush Cover	2
37	jackscrew M5*8	2
38	Carbon Brush House	2
39	42HD Cover	1
40	Screw M5*30	2
41	hose	1
42	hose coupler	1
43	Screw M5*45	2

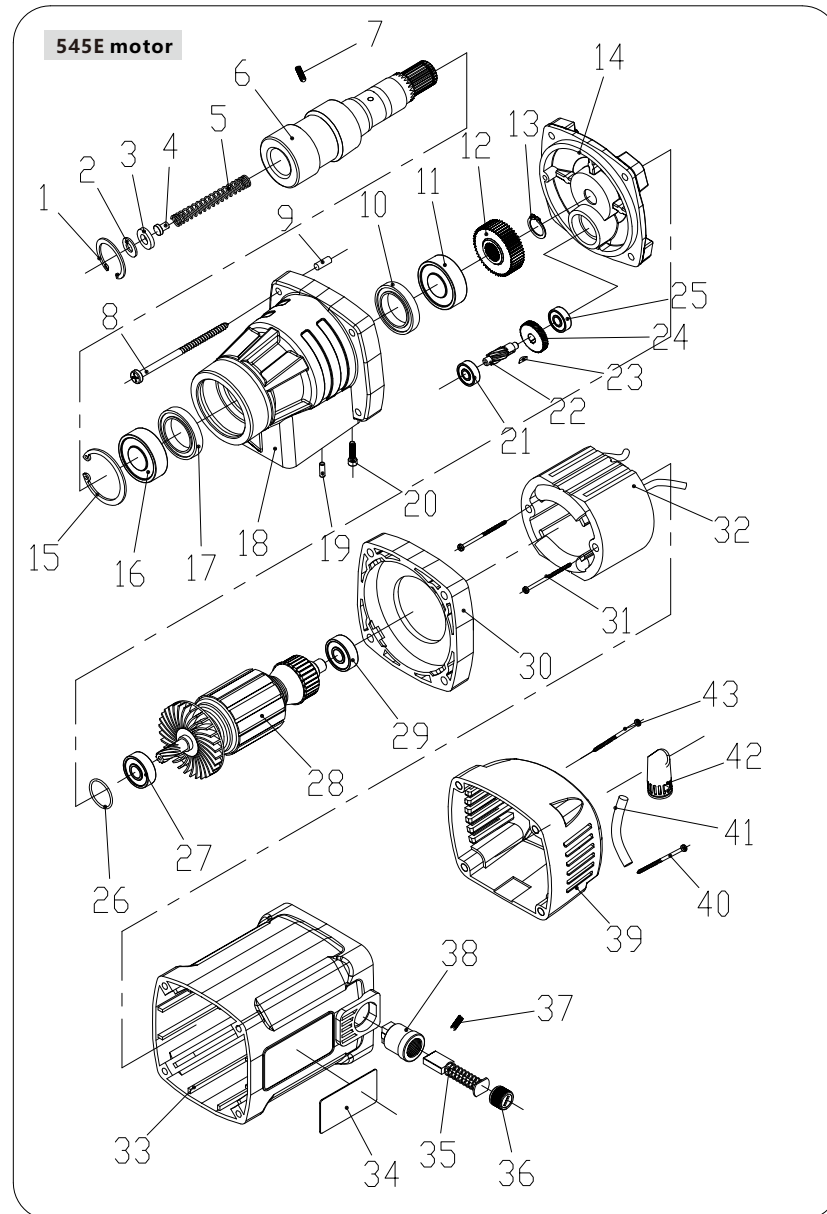

No.	Parts Name	QTY
1	Lifting Board 42HD 180*80	1
2	Rack 10*16*180	1
3	hose	1
4	Philip's head screwM3*8	3
5	roll pin	2
6	Dovetail slider	1
7	Dovetail stand	1
8	Adjustable slider3*12*230	1
9	E clamp ring 15	1
10	gasket17*30*1	1
11	Bearing6903	1
12	External Circlip 18	1
13	Lifting gear 18*44*16	1
14	copper sheathing58*26*30	1
15	Lift shaft 32HD-1	1
16	Square Pin 5*14	1
17	Inner Hexagonjackscrew M5*22	5
18	hose coupler	1
19	Screw M5*12	2
20	Rocker M10*145	3
21	Handle M10	3
22	Cable 3*0.75*2.5M	1
23	Label	1
24	Screw nut M4	1
25	Inner Hexagon Screw M4*16	1
26	Anti-bending joints M12*1.5	1
27	panel frame	1
28	speed regualtor	1
29	Switch KCD5	1
30	panel assembly	1
31	Stainless steel flat head screw	4
32	Motor Switch HY12-15	1
33	Speed control knob HY12-15	1
34	Fuse MF-527	1
35	circuit board	1
36	circuit board holder	1
37	Screw M4*10	2
38	Inner Hexagon screwsM4*10	4
39	Inner Hexagon screwsM6*55	2
40	magnetic disk 166*80*50	1
41	slider 1.5*11*230	1
42	screw nut M5	5
43	Inner Hexagon screwsM6*20	2
44	Backside panel	1
45	Stainless steel Screw M3*6	4
46		2

